

Zenith



DATA SHEET

**AGM BATTERY
HIGH CRANKING RATE
ZPC120035**

Performance features

PHCA	1100A at 27°C (80°F)	5 seconds
CCA	500A at -18°C (0°F)	
HCA	700A at 27°C (80°F)	
CA / MCA	600A at 0°C (32°F)	
Self-Discharge 25°C (77°F)	Capacity after 3 month storage	91%
	Capacity after 6 month storage	82%
	Capacity after 12 month storage	64%
Standard Terminal	M6M	
Reserve Capacity	70Min	
Charging Cycle (constant voltage)	Charge 14.5V~14.9V/ 25°C (77°F)	
	Float 13.6V~13.8V/ 25°C (77°F)	
Short circuit current	2.182A	
Operation temperature range	-15°C (-5°F) to 50°C (122°F)	

Specifications

Nominal Voltage		12V
Rated Capacity (20 hour rate)		40Ah
Dimension	Total Height (with terminals)	206mm (8.11 inches)
	Height	192mm (7.56 inches)
	Length	250mm (9.84 inches)
	Width	97mm (3.82 inches)
Weight		Approx. 14.9kg (32.85lbs)

High rate discharge at 25°C (77°F)

5 sec	10 sec	20 sec	30 sec
1100A	982A	830A	705A

Extended discharge at 25°C (77°F) to 10,02V

5 min.	15 min.	1h	3h	5h	10h	20h
174A	83.6A	28.8A	11.3A	7.15A	3.9A	2.1A

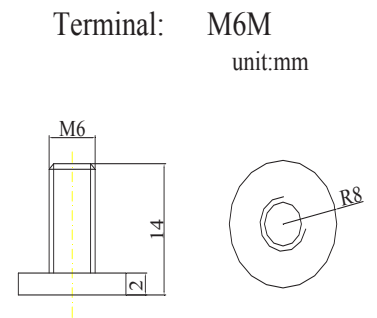
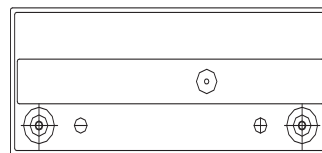
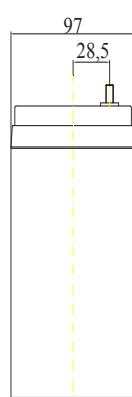
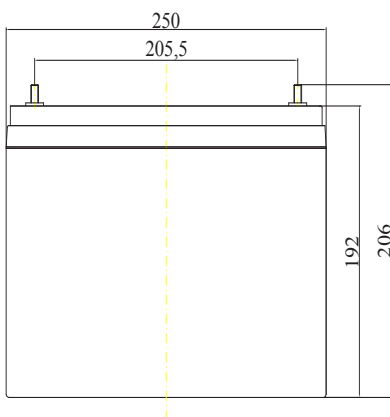

This information is generally descriptive only and is not intended to make or imply any representation, guarantee or warranty with respect to any cells and batteries. Cell and battery designs/specification are subject to modification without notice. Contact U.B.S. UNION BATTERY SERVICE for the latest information.

www.zenithdcbattery.com

DIVISION OF



www.unionbatteryservice.it