

# ZGL120098



### Constant Current Discharge Rating Amperes @ 25°C (77°F)

FV/Time	5M	10M	15M	30M	1HR	2HR	3HR	4HR	5HR	8HR	10HR	20HR
10.5	671.1	494.6	424.4	275.6	165.1	92.2	66.82	55.12	44.8	31.5	26.52	13.65

### Characteristics

Capacity	20 hour rate	260AH	
25°C (77°F)	5 hour rate	221AH	
Internal Resistance	Full charged Battery 25°C (77°F)	3.5mΩ	
Capacity affected by Temperature (20 hour rate)	40°C (104°F)	107%	
	25°C (77°F)	100%	
	0°C (32°F)	76%	
	-10°C (14°F)	66%	
Self-Discharge Batteries	can be stored for more than 6 months at 25°C. Self-discharge ratio less than 3% per month at 25°C. Please charge batteries before using.		
Standard Terminal	M8		
Max. Discharge Current 25°C (77°F)	2600A (5s)		
Final Discharge Voltage V/cell	1.75V	1.70V	1.60V
	(A) ≤ 0.2C	0.2 < (A) < 1.0C	(A) ≥ 1.0C
	Charging (Constant Voltage)	Cycle Initial Charging Current 78A Or Small 14.6V~14.8V/ 25°C (77°F) Float 13.6V~13.8V/ 25°C (77°F)	
Container Material	A.B.S. (UL94-HB), Flammability resistance of UL94-V1 can be available upon request.		

### Specifications

Nominal Voltage	12V	
Rated Capacity (20 hour rate)	260Ah	
Dimension	Total Height (with terminals)	224mm (8.826 inches)
	Height	220mm (8.66 inches)
	Length	520mm (20.47 inches)
	Width	268mm (10.55 inches)
Weight	Approx. 74.0 kg (162.8lbs)	

### Discharge characteristics 25°C (77°F)

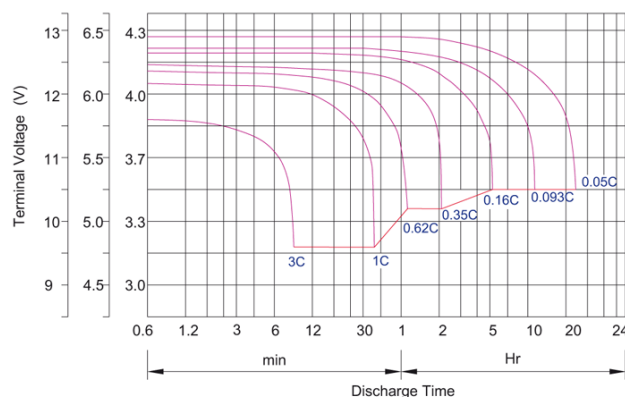

### Charge characteristic Curve for standby use

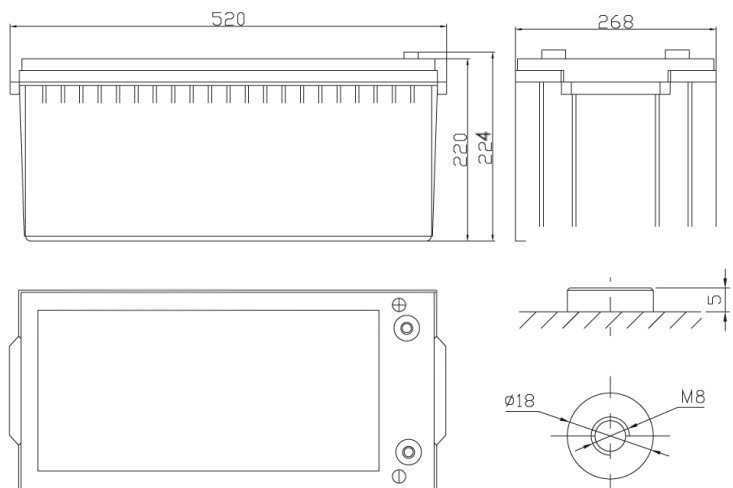
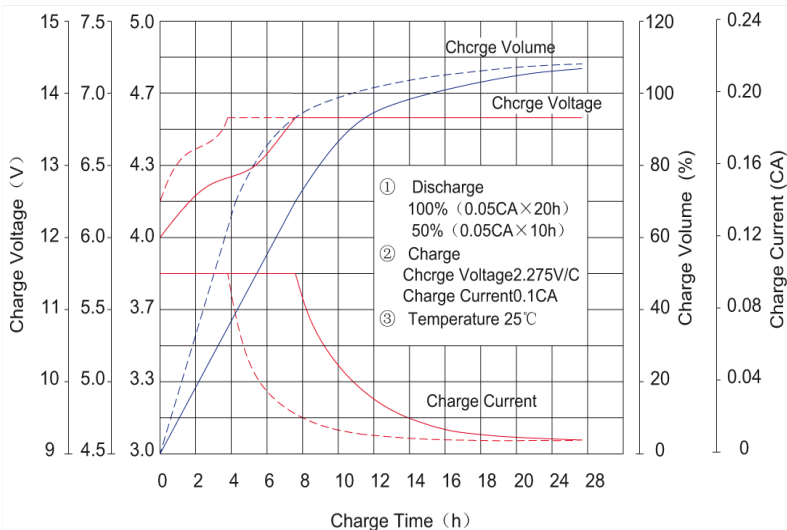

This information is generally descriptive only and is not intended to make or imply any representation, guarantee or warranty with respect to any cells and batteries. Cell and battery designs/specification are subject to modification without notice. Contact U.B.S. UNION BATTERY SERVICE for the latest information.

DIVISION OF



[www.zenithdcbattery.com](http://www.zenithdcbattery.com)