

# Owner's manual

## DC-series



Sound Quality / Integration Amplifiers  
With Full On-Board Processing and Zapco DPN

Before operating the unit, please read this manual thoroughly  
and retain it for future reference.

Protect your  Investment

Note your information below for reference:

Model # \_\_\_\_\_ Serial # \_\_\_\_\_

Date Purchased \_\_\_\_\_

And: *Register your Zapco product now*

At: [www.zapco.com](http://www.zapco.com)

# Mission Statement

## **ZAPCO IS DEDICATED TO THE PURSUIT OF AUDIO FIDELITY.**

Our passion, our "Driving Force" is to design and manufacture car audio products of unsurpassed quality, to provide unparalleled support and service for these products and to conduct business in a manner that will enhance the quality of life for all involved. There is absolutely no substitute for experience; that is a simple fact of life. Another simple fact is that for over 30 years, ZAPCO has been the leader in defining quality standards for the car audio industry. These years of experience have led to a thorough understanding of the challenges that are unique to the world of car audio. ZAPCO's relentless quest for sonic purity consistently yields imaginative designs that utilize the most innovative technologies. These sulting products set the criteria by which all others in the industry are judged. Feel the passion, hear the quality, know the performance and reliability by making ZAPCO the "Driving Force" in your car audio system.

### **Sonic Purity**

Our dedication to sonic purity requires that the highest quality internal components are used.

#### **Resistors**

All resistors (other than power resistors) are 1% precision low noise metal film. This is a key reason why ZAPCO products have the industries' best low noise specifications, and why you won't see as much fluctuation in our test certificates as you will with other brands. Precision resistors also reduce distortion and improve channel matching.

#### **Capacitors**

Capacitors are similar to batteries. Like a battery, they store energy and have electrolyte (internal fluid). Also like a battery, a capacitor can have a very limited life. "Computer grade" capacitors for example, are reliable only in cool environments with very little current applied to them. Only the best high current and high temperature capacitors should be used in an auto-sound application. Although these capacitors typically cost five times as much as those commonly used in other brands, ZAPCO insists that no audio degradation will occur over time.

#### **Transistors**

Two types of transistors are used in ZAPCO products, bipolar and MOSFET. MOSFET transistors are rugged, high current output devices that are best suited as switches. They are the choice for switching power supplies. They are however, very non-linear and are not suitable for use as audio outputs. They cannot be matched and their inherent distortion requires too much feedback to achieve reasonable distortion levels. Bipolar output transistors are used exclusively in the audio stage of all Reference Series amplifiers. The audio performance of a bipolar transistor heavily outweighs any minor advantages a MOSFET might offer regarding durability. We solve the durability concerns by simply using more output devices than the amplifier requires. This gives us a bulletproof amp with the sound quality we demand of a ZAPCO product.

## **Welcome to the World of Zapco Digital - 2012**

**For 2012:** Zapco takes you to the next level with the new Zapco DC-Series amps, with more control more features and speaker level inputs the make integration of the DC amps with a factory stereo a breeze

### **What's New for 2012**

First, of course, the DSP-Z8 has 2 more output channels than its predecessor. This allows an active 4-way system to be set up, or an active 3-way main system with a rear fill.

The crossover of the DSP-Z8 has been improved by allowing up to 36dB/Octave slopes for a sharper cut-off and better speaker protection.

The Signal delay function of the DSP-Z8 has more resolution, allowing adjustments down to 3mm

Direct Muting has been added and can be used by individual channels or by channel pairs

The new DSP-Z8 accepts speaker level inputs through its balanced RCA input connectors. You can just attach RCA connectors directly to the speaker outputs of a factory stereo (up to 22 Volts) and plug them right into the DSP-Z8.

A voltage sensitive EQ filter lets you activate an EQ filter at a predetermined input level to compensate for active factory equalization when integrating the processor and/or amplifiers into your factory stereo system.

In this manual we will take you through the programming and control functions of the Zapco DSP-Z8 and the on-board DSP in the Zapco DC Series of DSP controlled amplifiers as well networking operations of Zapco's DPN system.

## **Transformers**

Most of the transformers used in our products are hand-wound to ensure maximum quality. This provides a guarantee that current capability, efficiency, and radiated noise are all kept within our demanding parameters. Another critical aspect of the transformer is mounting; all transformers are securely mounted in their respective chassis. Transformers are massive, and if not securely mounted can cause failure among internal components due to vibration.

## **Power Supplies**

Regulated or Unregulated? For years amplifier designers have debated which type of power supply is best. What's the truth about power supplies? They each have advantages and disadvantages and there is no, one, best type. Limiting yourself to one type of power supply limits your amplifier design flexibility. ZAPCO uses both types of power supplies depending on the intended use of each amplifier, as well as expected current demands and operating environment.

## **Zapco Digital**

Who has the number one name in state of the art audio equipment?

**Zapco!**

But, when most people think of Zapco, they picture compact, powerful, great sounding amplifiers. While this picture is true enough, it misses one big piece of the Zapco legend.

## **Signal Processing!**

Zapco virtually created the concept of high sound quality processing in the late 70's when we created the PEQ. This was a high voltage preamp/EQ with and audiophile input stage and 9 bands of equalization for each channel. It brought a whole new level of performance to car sound. In the 90's the name was changed to SEQ and the unit is still in production today.

In the 80's we took processing to another new level with the PX. This was the first audiophile quality preamp EQ with a multi-order crossover. In addition, all four EQ bands were parametric, so now you could customize the EQ parameters to you car. The result: By the late 80's even non-Zapco dealers had to have a source of PX's for all their competition cars.

The next leap was in the 90's, when Zapco introduced the SX, (later to become the SX-SL). This unit expanded the Parametric EQ to 5 bands, added dual high pass and three way band pass crossovers, added variable crossover slopes, bass-to-highs balance, and SymbiLink™ Balanced inputs.

In 2004 Zapco Introduced the DSP-6, stand-alone, PC controlled Digital Signal Processor. We also introduced the DC Reference line of Amplifiers. These were the first ever PC controlled amplifiers with on-board DSP's for each and every channel. The DC Reference amps were controlled by the revolutionary Zapco DPN control network that allowed a single CP screen or DRC controller to control each amplifier in the system separately and to apply memory settings globally to the network.

## Welcome to the World of Zapco Digital - 2012

**For 2012:** Zapco takes you to the next level with the new Zapco DC-Series amps, with more control more features and speaker level inputs the make integration of the DC amps with a factory stereo a breeze

### What's New for 2012

First, of course, the DSP-Z8 has 2 more output channels than its predecessor. This allows an active 4-way system to be set up, or an active 3-way main system with a rear fill.

The crossover of the DSP-Z8 has been improved by allowing up to 36dB/Octave slopes for a sharper cut-off and better speaker protection.

The Signal delay function of the DSP-Z8 has more resolution, allowing adjustments down to 3mm

Direct Muting has been added and can be used by individual channels or by channel pairs

The new DSP-Z8 accepts speaker level inputs through its balanced RCA input connectors. You can just attach RCA connectors directly to the speaker outputs of a factory stereo (up to 22 Volts) and plug them right into the DSP-Z8.

A voltage sensitive EQ filter lets you activate an EQ filter at a predetermined input level to compensate for active factory equalization when integrating the processor and/or amplifiers into your factory stereo system.

In this manual we will take you through the programming and control functions of the Zapco DSP-Z8 and the on-board DSP in the Zapco DC Series of DSP controlled amplifiers as well networking operations of Zapco's DPN system.

## Addressing Components on the DPN

The Digital Programming Network consists of 10 amplifier/DSP nodes numbered 0 through 9. An extra node (number 10) can be occupied by the in-dash controller (DRC-SL).

**NOTE:** Turn all amps off before setting address switches

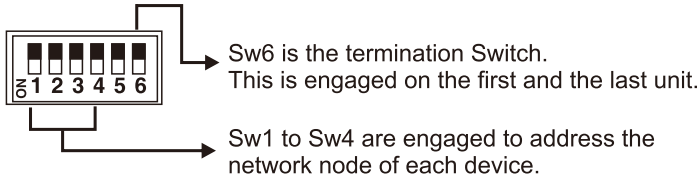

### Settings for Each Node

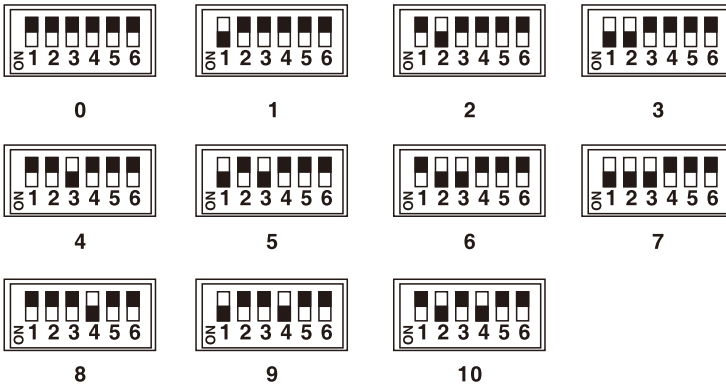

Up to 10 devices can be addressed using the DIP switch. Only the first 4 pins are for addressing the devices. Pin 5 is not used, and pin 6 is used only for the first and last units in the network.

## The Zapco Digital Programming Network

All Zapco DC series amplifiers, and the ZAPCO DSP-Z8, stand-alone Digital Signal Processor incorporate Zapco's exclusive Digital Programming Network™ (DPN). This network allows the user to program all amp functions using a DRC (Dash Remote) or a PC. The amps DSP can then be programmed to control Gain, Volume, Crossover, Equalization, and even Time Delay. More importantly, the system allows you to network all amps in your system so you can control up to 10 amplifiers from a single DRC or, with a PC from a single window.

While the DRC provides functions never before available, its small size does limit the graphics of the network and it takes a while to make the settings through the menu system. To allow higher resolution graphics and to make the setting go much faster, we have also developed a program that lets you make all adjustments with a PC. Each Digital Control product has a USB interface. This allows you to plug a PC into any unit on the network and control the entire network.

The amp's DIP Switch allows you to address each amplifier to it's own location on the network. Then when you call up the amp for programming, it will even identify itself by its location and its model number.

USB input allows a PC to be hooked directly to the amp with a standard USB cable. The DRC-SL also has a USB port so the PC can be plugged in at the dash, without disturbing the installation.

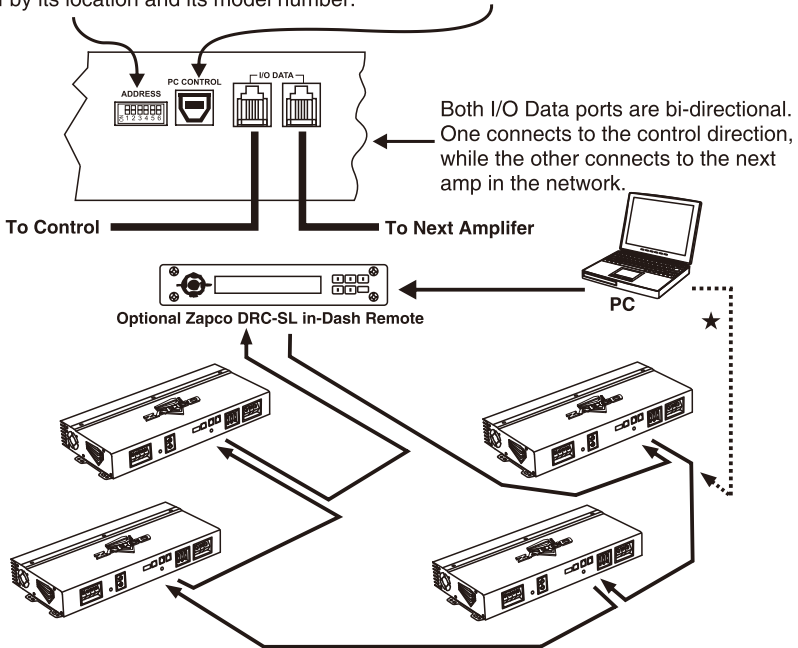



Since the programming of the DSP-Z8 and the DC Series amplifiers are the same we will begin with the DSP-Z8 and how the programming works. Then we will review the DC Series amplifiers.

## DSP-Z8 : Six In / Eight Out Channel Digital Signal Processor

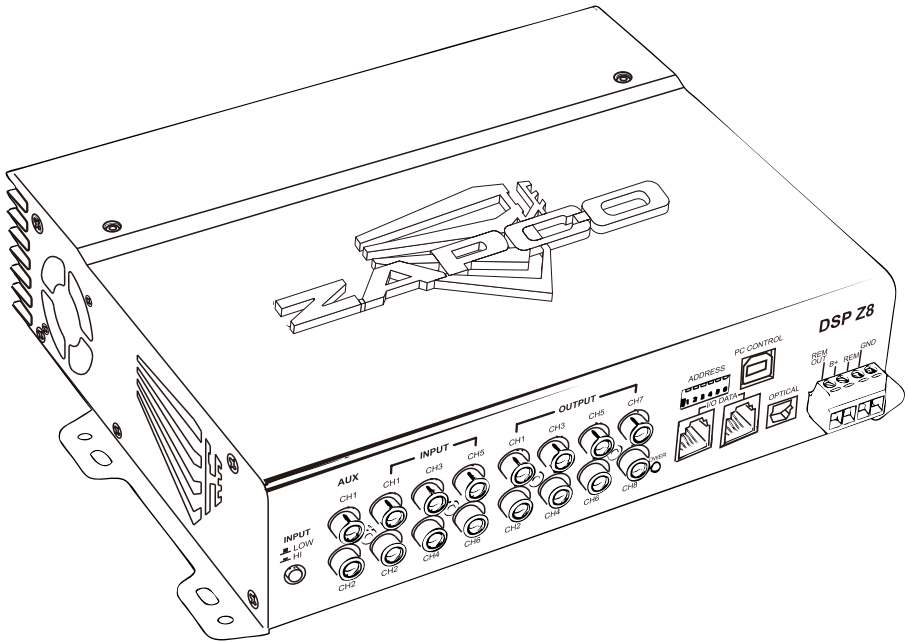

### Specifications

THD:

Analog < 0.0015

Digital < 0.0008

Sensitivity 0.5V to 22V

S/N Ratio:

Digital > 100dB

Analog > 99dB

Control Input Mini USB

Dimensions 220mm(L) x 55mm(H) x 180mm(W)

## DSP-Z8 Connection Panel

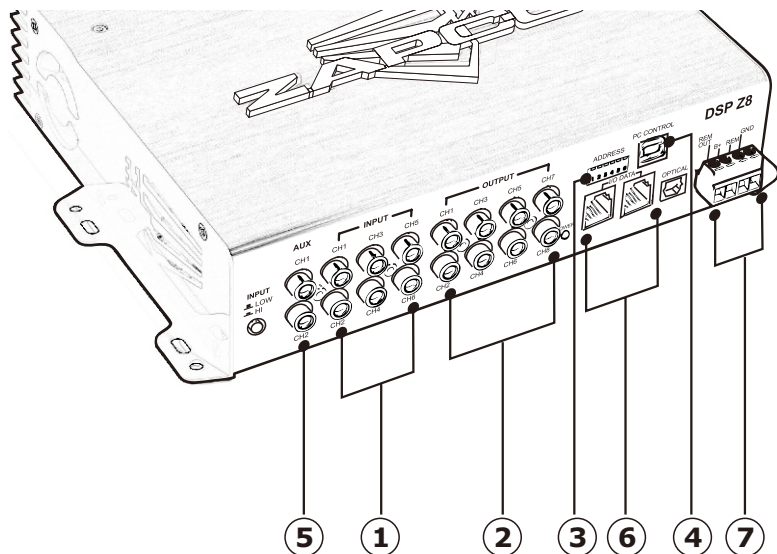

### Front Panel Connections

- 1) RCA Inputs- **Six channels of input are available through RCA connectors\*.**
- 2) RCA Outputs-**4 sets of RCA Connectors provide eight channels of output.**
- 3) DIP Switch-**Six position DIP switch is used to address the unit and assign a node on the Zapco Digital Programming Network.**
- 4) USB Port- **Like all Zapco DC products, the DSP-Z8 has a USB port to interface with a PC for all DSP programming functions.**
- 5) Auxiliary Input  
 Digital Input- **Optical connector for SPDIF input**  
 Analog- **RCA connector for analog Aux-in**
- 6) Data Connectors- **Two RG connectors provide Data in/out for network cables (and DRC control input)**
- 7) Power Connector- **Provides Power, Ground, Turn On, and Aux +12 volt out \*\***

**\* Note:** To use speaker level inputs from a factory stereo, simply attach RCA connectors to the factory speaker wires (up to a 22v signal). Assure that the DSP or amplifier is in High Level input mode and plug the speaker wires directly into the RCA inputs.

**\*\* Note:** The Zapco DC Series also has DC-offset sensing for automatic turn-on. If you use speaker level inputs from a factory stereo the DC product will turn on automatically and also provide +12v trigger output to turn on other components.

## Zapco Digital – Functions and Control

The Zapco DSP-Z8 is a stand-alone eight channel Digital Signal Processor. It has all the DSP functions of the Reference Digital amps, but, as a stand-alone piece, it brings the world of Zapco Digital to any amplifier.

The RCA inputs allow you to use the DSP-Z8 with any after market head unit, and two auxiliary inputs allow an extra input by either RCA or SPDIF Digital. The DSP-Z8 and all Zapco DC Series amplifiers will also accept balanced speaker level signals from a factory amplified system to add high-end sound to factory stereos.

The Zapco Digital functions include Input Sensitivity, Output Gain, Crossover, Equalization, and Time Delay. Each Reference Digital piece also has an Input Commutator that allows any input to be assigned to any output. The Commutator also allows input pairs to be summed for a 2-channel mono input to any output channel. In addition, you can combine input channels together to sum their signals for integrating actively crossed over signals to a single full range signal. All DSP functions may be applied to each channel independently or they may be applied in stereo pairs.

**Control Methods:** Zapco provides two options for control of the Zapco Digital functions. First; you can load the program included with your digital product into a PC and program all functions directly from the programming screen. You will find all functions on a single, easy to use, screen.

The other Zapco Digital control option is the Zapco DRC. The DRC is an in-dash piece with a Graphic LCD display and will access all Zapco Digital functions. Because of the size limitations of the DRC screen, this unit will take longer to operate than the PC, however unlike the PC, the DRC can be mounted in-dash and will always be available for needed adjustments.

## The PC Program

A program disk was included with your Digital Reference Amplifier. The program will work on any Windows OS from 95 forward. To install, insert CD and browse to the CD-drive. From the folder [Zapco DPN Program], run Zapco DPN Program.exe to install.

## Zapco Digital Control Screen

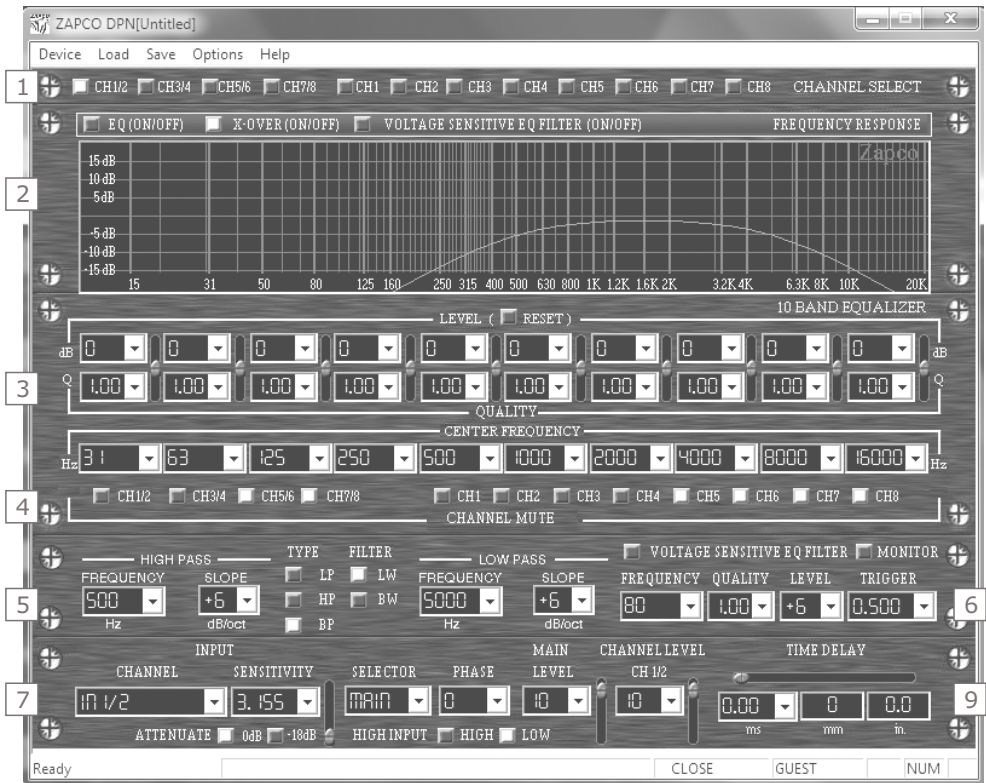

## The PC Programming Screen

The PC programming screen has 5 sections. They are (top to bottom) Channel Select, Function/Graph, Equalizer, Crossover, and Input/Delay. We will consider these sections individually and we think you will find the controls very user friendly.

There are numerous drop-down menus at the arrow points in the DSP screen. You can use the drop-down arrows to make choices, or simply highlight the box you want to change and type in your choice manually. Most small boxes are switches and are switched by placing the mouse over them and clicking you will also find that you can click into most adjustments and use your scroll wheel to change the values.

For example: If you click the slider of a EQ level, your scroll wheel will move the level 1dB per scroll step, you can also click on the slider and "drag" it or you can highlight the value and type in a new value. Chose the method you find most convenient.

**1) Channel Select** The top section of the PC screen allows you to determine which available channels you will be programming. The number of options will be determined by the Zapco Digital item you are programming. The Zapco Digital Control will identify which unit you are programming and how many channels are available. You can adjust the channels individually, or in stereo pairs as required. Simply move the mouse to your choice and click it on.

**2) Function/Graph** In this section you can turn the processing functions on or off to compare the sound of your modified response to the unprocessed sound by clicking the buttons on or off with your mouse. You can also monitor the graph to see, in real time, how your adjustments will affect the input signal.

**3) Equalizer** In this section you can make the adjustments to the parametric equalizer. The top row sets the level of boost or cut at the center frequency, up to  $\pm 15$ dB. The next row sets the Q (shape) of the equalization. A low Q affects a wide range of frequencies while a high Q affects a narrow range of frequencies. The Graph screen will let you see how the different Qs affect your response. The bottom row of the EQ screen sets the center frequencies. The EQ section is a true parametric EQ. We have set factory defaults at about  $\frac{1}{2}$  octave intervals. However you can alter the center frequencies to fit the requirements of your car.

**4) Mute** The Mute buttons allow you to temporarily turn off some of the active channels. This is very handy in tuning when you want to hear the response of an individual channel.

**5) Crossover** For each channel, when you have turned on the crossover function, you can choose to run a High pass, a Low pass, or a Band pass crossover. You can also choose a crossover slope of 6dB, 12dB, 24dB, or 36dB per octave. From the drop-down menu, and you can choose to use a Butterworth or a Linkwitz-Riley filter.

**6) Voltage Sensitive EQ** Allows you to set one parametric EQ filter for each channel or channel pair that will come on only then the system reaches a pre determined volume. This is most often used in factory integration when the factory system rolls off the bass frequencies to protect the factory woofer. See more under **Getting Started** later in this manual

**7) Input** This lower section of the screen contains the Input Commutator, Source Selector and Phase control

**Channel** At the top of the screen you picked the channel you would adjust. Here you can pick which channel you will use as input for the chosen channel. In this way you can assign the same channel pair as input to all channels of multi-channel amps.

**NOTE: Ch5+6** (as above) means you will "sum" the two channels to a single mono input.

**Ch5/6** means you will use channels 5 and 6 as a stereo input pair.

**Also:** The Input Channel selector gives you the option of summing 2 or 3 stereo pair into one single stereo pair for OEM integration. This lets you combine highs, mids, and lows from a factory system into a single stereo output and eliminate the factory crossover.

**Sensitivity:** After picking the inputs for your channels, you can set the channel's sensitivity for maximum signal with minimum noise. Input voltage should be set to match the head unit's output.

**Selector:** Allows you to choose from the Main input, the Analog Aux-in, or the Digital SPDIF input

**8) Output** After the sensitivity has been set at optimum for all channels you can control the maximum system volume with the Main output control and balance the channels by attenuating the output of the louder channels to bring all channels into correct acoustic balance with the individual channel output levels..

**9) Signal Delay:** Time delay allows you to adjust the arrival time of each speaker's output by delaying the closer speakers. This will improve the sound stage and provide superior imaging and balance. With the Zapco Digital pieces this is an easy operation.

- 1) Measure the distance from your head (at your listening position) to each speaker in millimeters or inches.
- 2) Note the distance of the farthest speaker.
- 3) Add to each speaker the inches need to equal the furthest speaker, and note how many inches are needed for each.
- 4) Now just dial in the delay to match the added inches for each speaker and your delay is set.

## **Program Upgrades**

The Zapco Digital Programming Network is an evolving entity. As it evolves we can issue program updates.

If there are firmware upgrades we will issue a new hex code which you can place on your desktop. The upgrade process is straightforward.

- o Note the COM port your program is using then close the program
- o Open the Zapco Updater (on the disk) and:
  - set the COM port to match what the system is using
  - Browse to the new HEX file and click it into the Zapco Updater
- o Turn the system off and back on and the system will update.
- o When updating is finished, close the updater, and your done.

## Optional DSP-Z8 Dash Remote

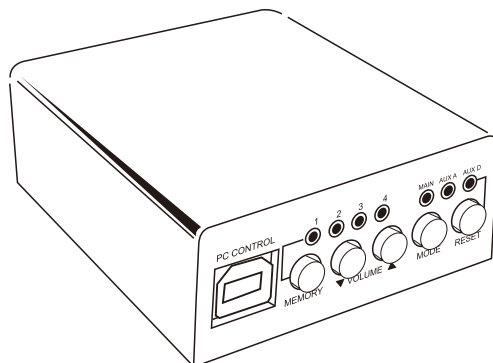

### The Zapco Z8-R

The Zapco Z8-R is an optional Dash Remote available for those who will use the auxiliary inputs of the DSP-Z8. The Z8-R allows auxiliary functions to be accessed without the need to have a PC connected to the system while on the road. (Safety First Please)

First, the Z8-R provides a switching system (MODE button) so the user can toggle between the Main-In, the analog RCA input (AUX A) and the Digital SPDIF input (Aux D). Three LED indicators let the user know which input is currently active.

Since almost all digital inputs will be full gain out from the source, using the digital input will require a remote gain control. A pair of Up/Down buttons allow you to control overall volume in 1/2 dB steps. Again: Digital inputs are usually full gain, so you must take care to avoid surprises and dangerous distractions of abrupt volume changes. We highly recommend that if you are using the Aux-D input in your system, you should set your head unit to maximum unclipped output (usually about 3/4 volume), and use the Z8-R as your main volume control. *This way switching from Main input to Aux-D input will not cause severe volume changes.*

The Z8-R also provides memory switching. The DSP-Z8 lets you set up several global tuning systems for different types of music or for different listening needs (Say for sitting and listening to the music or when you need background music without bass for when the kids are in the car). With the Z8-R you can change which memory setting is active at any time, without the PC connected. Four LED indicators let you see at a glance which memory setting is active.

The Z8-R has a USB connector on the front panel. If you have the Z8-R mounted in the dash or in the glove box, you can plug your PC into the system for tuning right from the front seat.

The Z8-R also has a "reset" button. This button will only be used only if the system should need to be updated with future program changes.

## Read, Use, and Enjoy

Yes, please read this manual thoroughly. We wrote it to help ensure that you get the most from your investment in your Zapco amplifier. If you find, after reading the manual, that you still have questions please feel free to give us a call at 1(800)47-FORCE, or, drop us a note at [www.zapco.com](http://www.zapco.com)

## Power and Wire Gauge

The wire you use for the power and ground connections of your amplifier are absolutely critical. The plain simple fact is that it takes power to deliver power. If you do not provide the proper amount of 12V power to your amplifier, you will never reach the full power potential of your amp. Take a look at the chart below. If you want to have any respectable amount of power for your amp, you need an 4-gauge wire to the trunk as a bare minimum. If you are running any Zapco ZX-series amp in you trunk you need at least an 0 gauge wire.

## Recommended Wire Gauge

Up to	4 Ft	7 Ft	10 Ft	13 Ft	16 Ft	19 Ft	22 Ft	28 Ft
<b>20 A</b>	14	12	12	10	10	8	8	8
<b>35 A</b>	12	10	8	8	4	4	4	4
<b>50 A</b>	10	8	8	4	4	4	4	4
<b>60 A</b>	8	8	4	4	4	4	4	2
<b>85 A</b>	4	4	4	4	2	2	2	0
<b>105 A</b>	4	4	4	2	2	2	2	0
<b>125 A</b>	4	4	4	2	2	0	0	0
<b>150 A</b>	2	2	2	2	0	0	0	0

You can certainly save money by buying cheap small gauge wire, but remember...It will cost you in power and may even damage your car by passing too much current and causing shorts or even fires. Protect your investment in Zapco amplifiers by using high quality, proper gauge wire.

**And remember...** Current in the amplifier runs in a complete circuit from the battery to the amp and back to the battery through the chassis and frame. The ground wire is just as important as the power input wire. **Positive and Negative connections must always use the same gauge wire.**

## Installation Guidelines

Mounting your Reference Amplifier is easy. Keep in mind the following guidelines:

- The amplifier may be mounted in any direction, on wood, metal or carpet. The metal case of the amplifier may be grounded or left isolated.
- The amplifier requires adequate ventilation. Position the amplifier with sufficient surrounding area for proper cooling. Keep fan and vent endplates clear for proper internal cooling.



- Keep the amplifier out of the engine compartment and other locations that may cause excessive heat or moisture.
- Make sure your ground point is at the frame or a chassis point with direct frame contact. Note: the "quiet metal" on many new cars make body panels very bad ground points, so always try to use the frame.
- Do not mount the amplifier to a subwoofer enclosure or any other place that may have excessive vibration!

## **Gain Setting**

### **Matching Your Components for Best Sound**

Proper gain setting is one of the most important factors in setting up a stereo system. At the same time, gain setting is most often done wrong. Turning up the gain of an amp is the very last thing you should ever do to a system.

An amplifier is a step up transformer. Period. Any signal you put in is boosted by a fixed factor. Music, hiss, or any other noise, it doesn't matter. A large number of noise problems are simply a matter of improper gain settings. The goal of gain setting is to achieve the maximum amount of musical output from the amplifier while getting the least amount of hiss or noise from the system. Your Z-Series Series amplifier accepts an extremely wide range of input levels. As little as .5 volts on the RCAs to as much as 8 volts. The basic gain setting is very simple and requires no special tools. Whether you have a simple system with a deck and an amp, or a system with a deck, line driver, equalizer, crossover, and amp, the procedure is always the same. First, hook up the system with all gain controls at minimum (turn the gain pot fully counter-clockwise with a small screwdriver). Then turn on the head unit and turn up the volume. If you achieve clean sound, and, more volume than you want, you don't need to make any adjustments. However, if you turn up the volume and begin to hear distorted sound before it becomes loud, you are clipping (distorting) the deck (probably a little over  $\frac{3}{4}$  volume). Turn the deck down just enough to hear clean sound again, and then move to the next component in your system. With the deck playing at "maximum clean volume" adjust the gain of the next component to its "maximum clean volume". If you adjust your gains this way, always starting at the head unit and working down the line to the amplifier, you will get the most performance out of your amplifier(s) with the least amount of unwanted distortion and noise.

## **Presenting**

### **The Zapco DC-Series**

### **Sound Quality / Integration Amplifiers**

# FEATURES

## ■ DC-352 / DC-752

- On-board, full function DSP
- Bridgeable
- Intelligent rail voltage control
- Stable into 4 ohms bridged or 2 ohms stereo load
- USB input for PC control
- Signal input RCA connectors
- Optional digital programming network
- Ducted flow cooling
- Heavy-Duty, high-current, insulated terminal blocks
- Space saving flush wiring connections
- Three-channel capable
- Gate drive boost circuit
- High-current biolar outputs
- Optically isolated MOSFET power supply
- Quality ZAPCO construction

## ■ DC-364 / DC-1004

- On-board, full function DSP
- Bridgeable
- Intelligent rail voltage control
- Stable into 4 ohms bridged or 2 ohms stereo load
- USB input for PC control
- Signal input RCA connectors
- Optional digital programming network
- Ducted flow cooling
- Heavy-Duty, high-current, insulated terminal blocks
- Space saving flush wiring connections
- Tree-channel capable
- Gate drive boost circuit
- High-current biolar outputs
- Optically isolated MOSFET power supply
- Quality ZAPCO construction

## ■ DC-501 / DC-1101

- On-board, full function DSP
- Intelligent rail voltage control
- Stable into 2 ohms
- USB input for PC control
- Signal input RCA connectors
- Optional digital programming network
- Ducted flow cooling
- ZAPCO EHVC output circuitry
- Heavy-Duty, high-current, insulated terminal blocks
- Space saving flush wiring connections
- Gate drive boost circuit
- High-current biolar outputs
- Optically isolated MOSFET power supply
- Quality ZAPCO construction

# FEATURES

## ■ DC-656

- On-board, full function DSP
- Bridgeable
- Intelligent rail voltage control
- Stable into 4 ohms bridged or 2 ohms stereo load
- USB input for PC control
- Signal input RCA connectors
- Optional digital programming network
- Ducted flow cooling
- Heavy-Duty, high-current, insulated terminal blocks
- Space saving flush wiring connections
- Tree-channel capable
- Gate drive boost circuit
- High-current biolar outputs
- Optically isolated MOSFET power supply
- Quality ZAPCO construction

### ZAPCO DIGITAL PROGRAMMING NETWORK

The amp's DIP Switch allows you to address each amplifier to its own location on the network. Then when you call up the amp for programming, it will even identify itself by its location and its model number

Both I/O Data ports are bi-directional. One connects to the control direction, while the other connects to the next amp in the network.

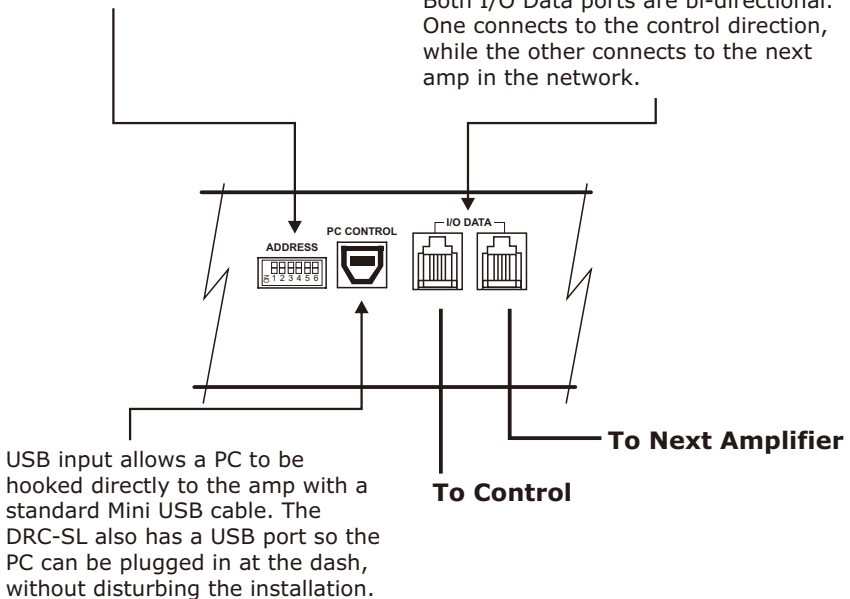

# CONNECTION

## ■ DC-352 / DC-752

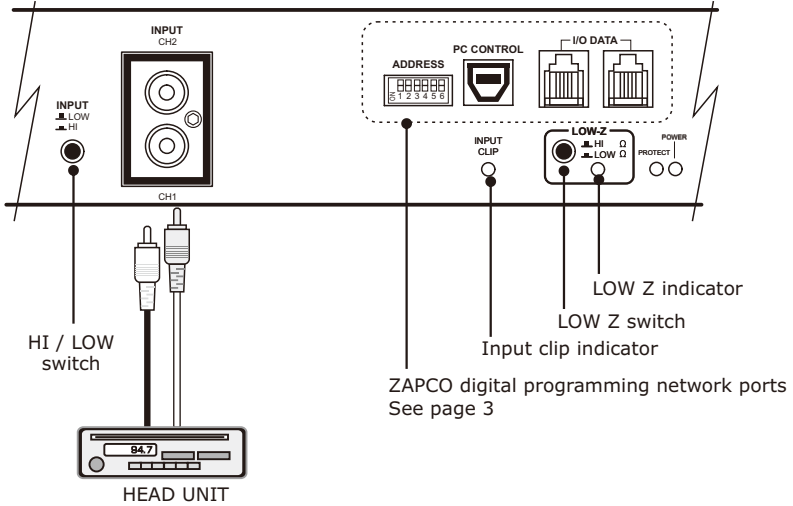

## ■ DC-364 / DC-1004

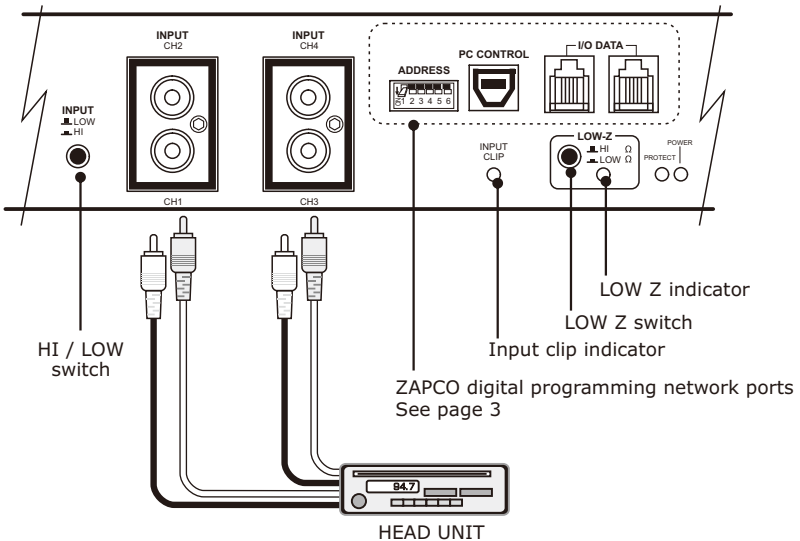

This amplifier has a signal input terminal of RCA connector type for low level inputs. Adjustment of input levels is accomplished by the gain control of both channels. Adjusting this control allows the amplifier gain to be controlled to match and balance both channels. The RCA input connector should be used when connecting the radio/cassette line out and this connection is usually made using RCA-RCA connector wires.

# CONNECTION

## ■ DC-501 / DC-1101

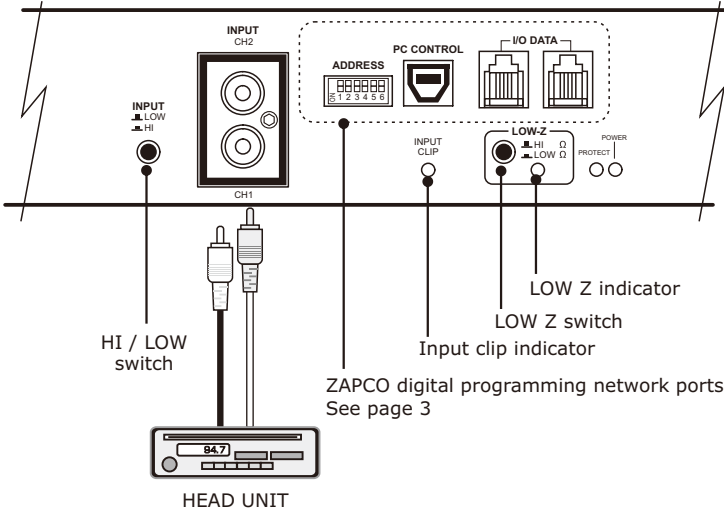

## ■ DC-656

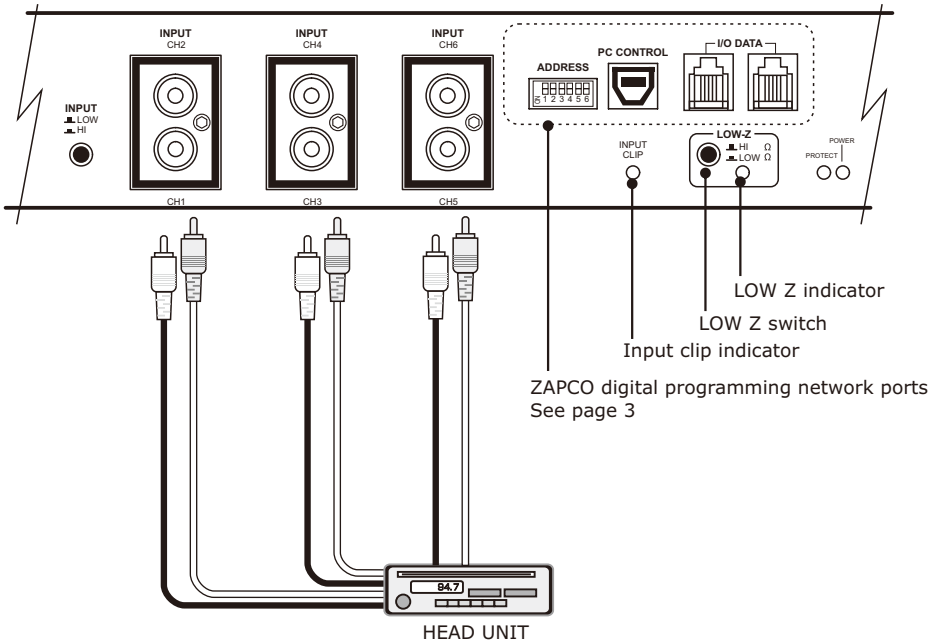

This amplifier has a signal input terminal of RCA connector type for low level inputs. Adjustment of input levels is accomplished by the gain control of both channels. Adjusting this control allows the amplifier gain to be controlled to match and balance both channels. The RCA input connector should be used when connecting the radio/cassette line out and this connection is usually made using RCA-RCA connector wires.

# POWER CONNECTION

## ■ DC-352/DC-752/DC-364/DC-1004/DC-501/DC-1101/DC-656

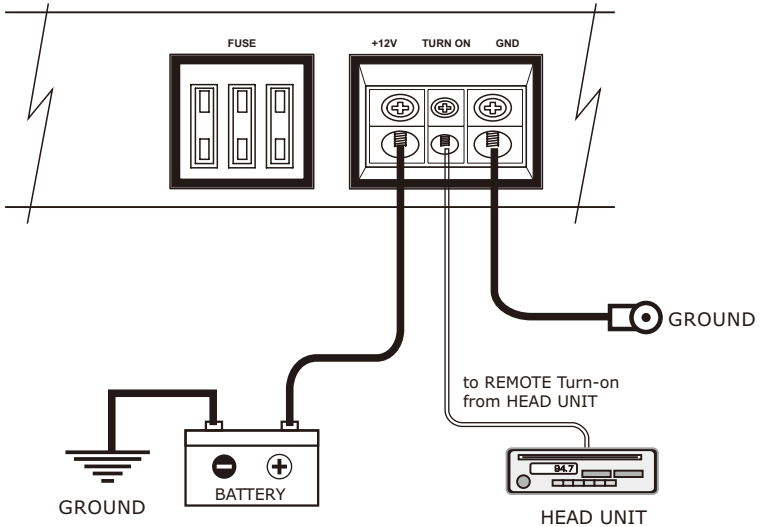

### **+12V Power**

Connect the +12V terminal of the amplifier to the + terminal of the battery using the same diameters the ground cable, making sure you install in-line fuse holder, approximately 300 or 400 mm. From the + terminal of battery, making sure that there is no fuse in the battery holder.

### **GROUND**

Disconnect the battery and connect the GND (ground) terminal to the cars chassis. Keep this cable as short as possible (not longer than 500 mm. or less). Making sure that the connection with the chassis is rust free and clear of paint or grime.

### **REMOTE**

Connect the REM terminal of the amplifier to the power antenna terminal in the car ignition switch using 12 or 16 ga. electrical wire.

### **⚠ Caution**

First make the ground connection, then +12V wire connection, and finally the remote connection. Furthermore, the +12V wire must always be fused at the battery for protection against possible damage. If you need to replace the power fuse, replace it with a fuse of the same value. It may result in a serious hazard to use a fuse of a different type or rating.

# SPEAKER CONNECTION

## ■ DC-352 / DC-752

### 1 Channel Bridged

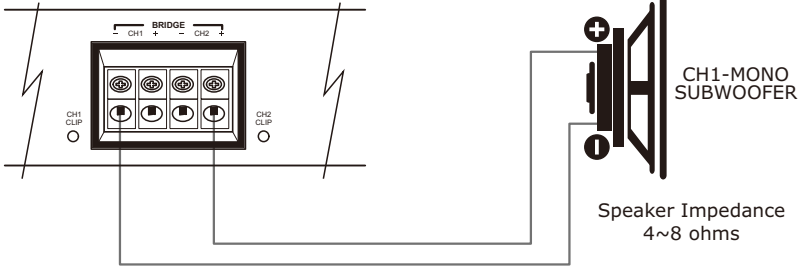

### 2 Channel Stereo

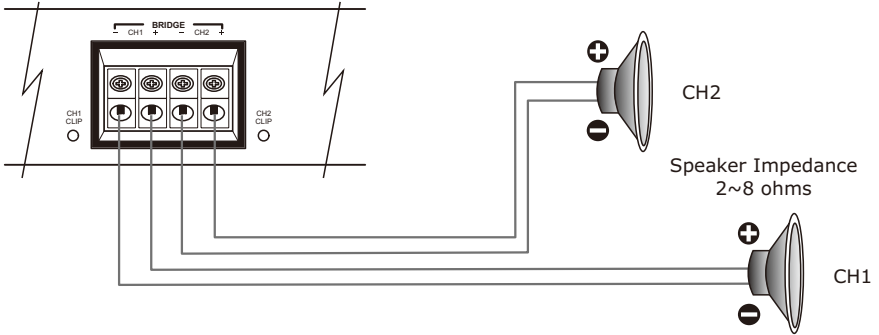

### 3 Channel Tri Mode

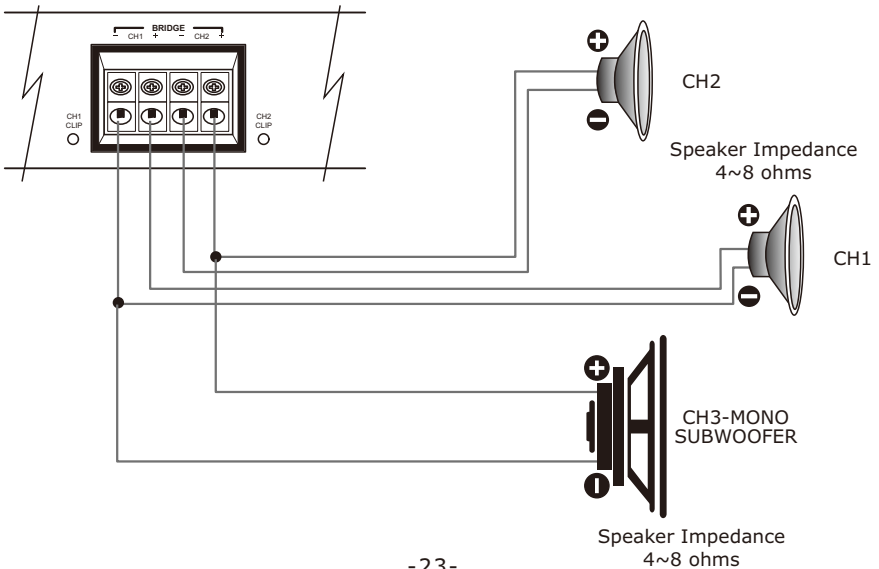

# SPEAKER CONNECTION

## ■ DC-364 / DC-1004

### 2 Channel Bridged

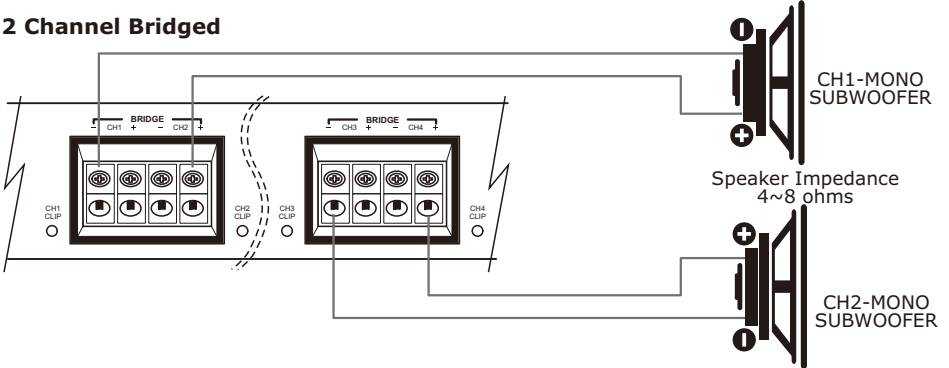

### 4 Channel Stereo

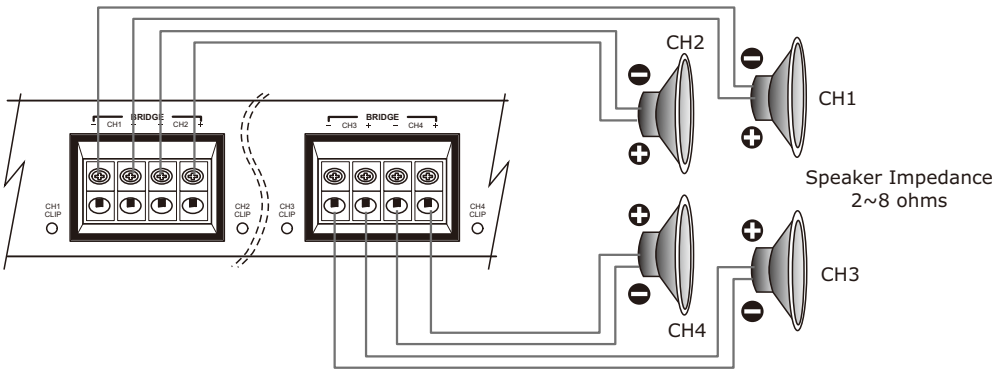

### 6 Channel Tri Mode

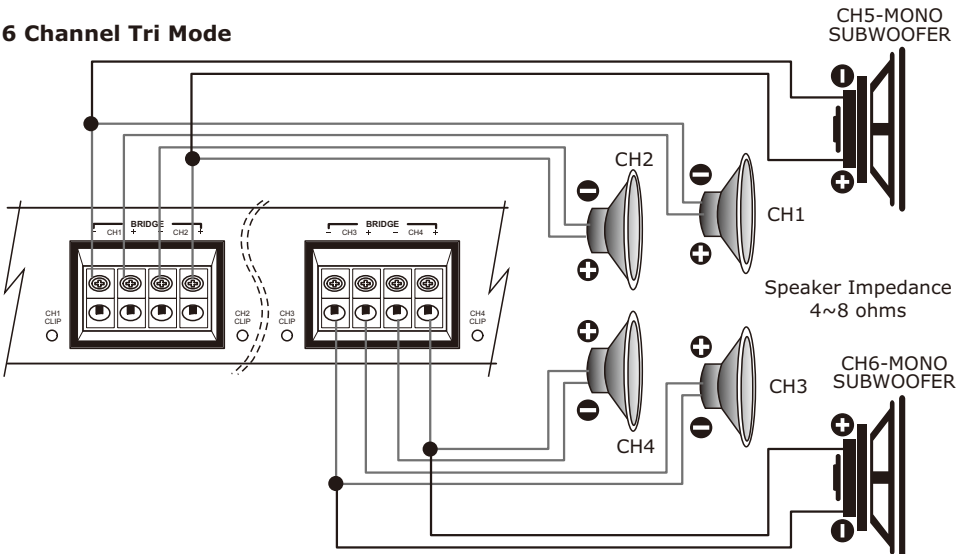



# SPEAKER CONNECTION

## ■ DC-501 / DC-1101

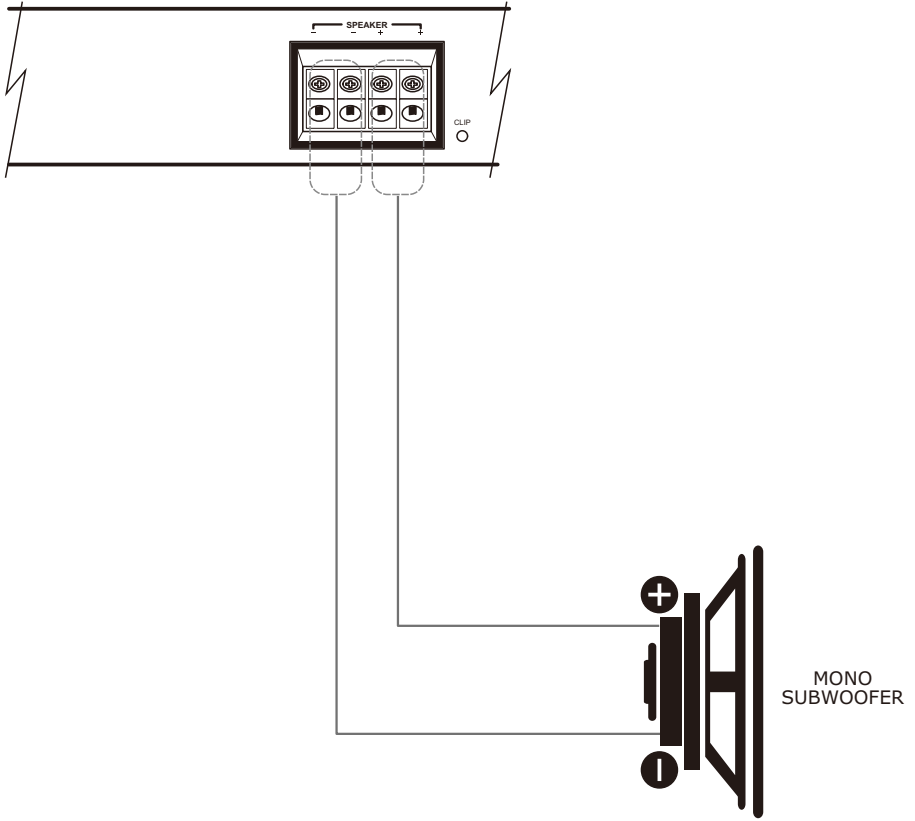

# SPEAKER CONNECTION

## ■ DC-656

### 3 Channel Mode

Speaker Impedance  
4~8 ohms

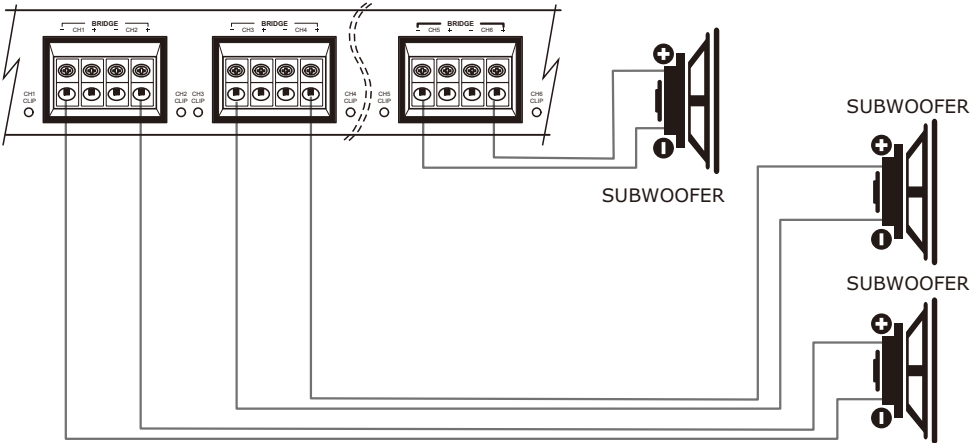

### 5 Channel Stereo

SUBWOOFER

Speaker Impedance  
4~8 ohms

Speaker Impedance  
2~8 ohms

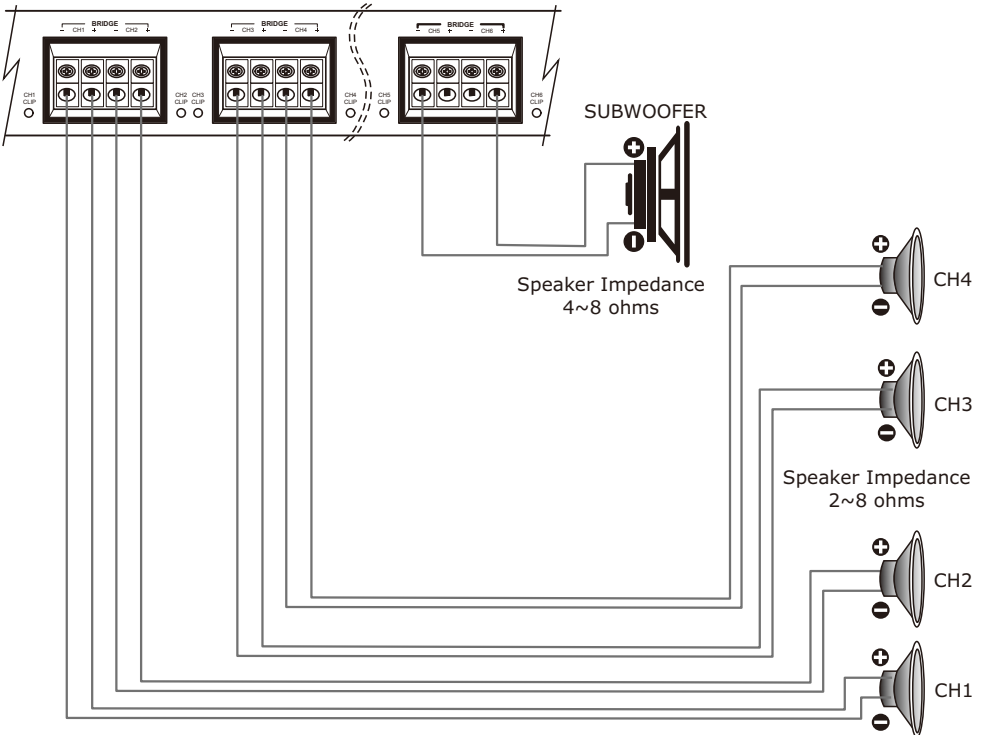

# SPEAKER CONNECTION

## ■ DC-656

### 6 Channel Mode

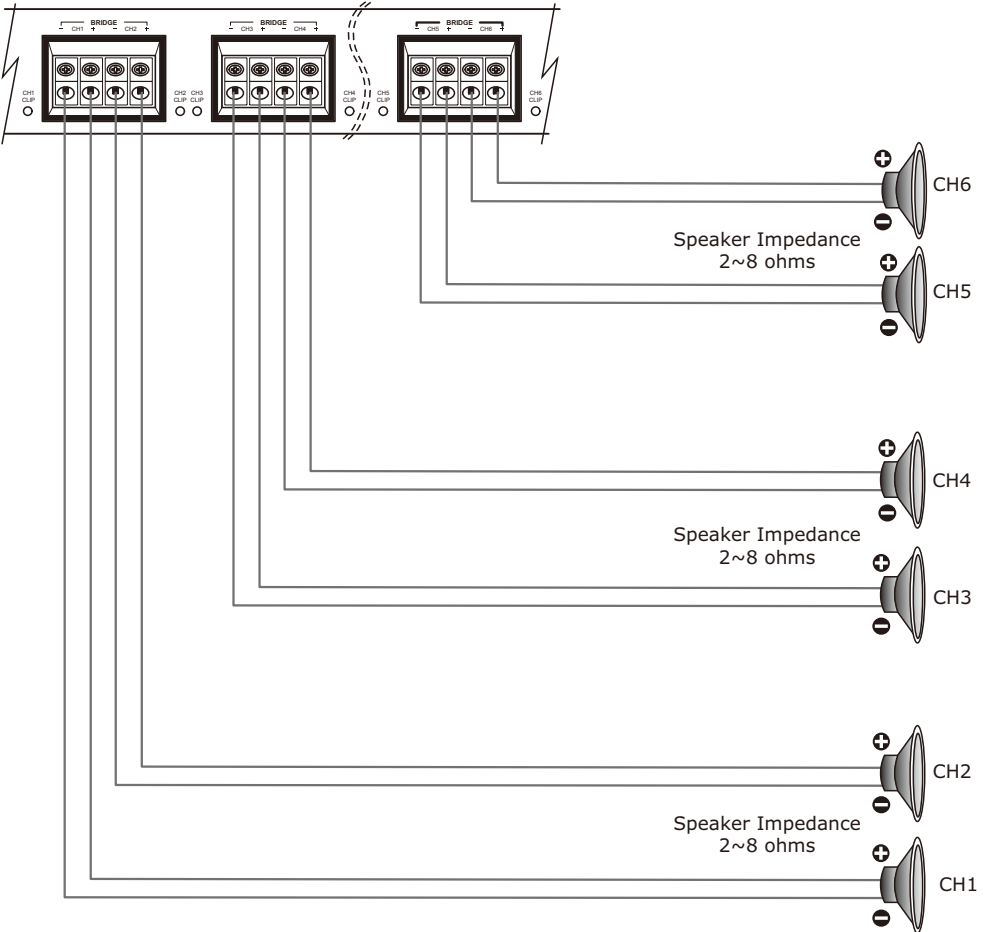

# SPECIFICATIONS

## ■ DC-352

## ■ DC-752

Rated power output

-RMS power, 4 ohms stereo -----	<b>100W x 2CH</b>	<b>200W x 2CH</b>
-RMS power, 2 ohms stereo -----	<b>200W x 2CH</b>	<b>370W x 2CH</b>
-RMS power, 8 ohms bridged -----	-	-
-RMS power, 4 ohms bridged -----	<b>418W x 1CH</b>	<b>780W x 1CH</b>
Signal to Noise Ratio -----	<b>&gt;96dB</b>	<b>&gt;90dB</b>
Frequency Response -----	<b>20Hz ~ 20KHz (+/-0.25dB)</b>	<b>20Hz ~ 20KHz (+/-0.5dB)</b>
THD@RMS Watts -----	<b>0.06%</b>	<b>0.05%</b>
Slew rate -----	<b>&gt;29 V/μS</b>	<b>&gt;40 V/μS</b>
Channel Separation -----	<b>66dB</b>	<b>60dB</b>
Damping factor -----	<b>&gt;800@4Ω</b>	<b>&gt;1000@4Ω</b>
Fuse Rating -----	<b>15A x 3</b>	<b>30A x 3</b>
Input Sensitivity -----	<b>500mV~10V (+/- 5%)</b>	<b>560mV~10V (+/- 5%)</b>
Dimensions (mm) -----	<b>400(L) x 55(H) x 180(W)</b>	<b>600(L) x 55(H) x 180(W)</b>

## ■ DC-364

## ■ DC-1004

Rated power output

-RMS power, 4 ohms stereo -----	<b>50W x 4CH</b>	<b>150W x 4CH</b>
-RMS power, 2 ohms stereo -----	<b>90W x 4CH</b>	<b>250W x 4CH</b>
-RMS power, 8 ohms bridged -----	-	-
-RMS power, 4 ohms bridged -----	<b>180W x 2CH</b>	<b>500W x 2CH</b>
Signal to Noise Ratio -----	<b>&gt;95dB</b>	<b>&gt;95dB</b>
Frequency Response -----	<b>20Hz ~ 20KHz (+/-0.12dB)</b>	<b>20Hz ~ 20KHz (+/-0.5dB)</b>
THD@RMS Watts -----	<b>0.01%</b>	<b>0.03%</b>
Slew rate -----	<b>&gt;23 V/μS</b>	<b>&gt;36 V/μS</b>
Channel Separation -----	<b>55dB(front) / 58dB(rear)</b>	<b>60dB</b>
Damping factor -----	<b>&gt;500@4Ω</b>	<b>&gt;800@4Ω</b>
Fuse Rating -----	<b>15A x 3</b>	<b>30A x 3</b>
Input Sensitivity -----	<b>500mV~10V (+/- 5%)</b>	<b>500mV~10V (+/- 5%)</b>
Dimensions (mm) -----	<b>480(L) x 55(H) x 180(W)</b>	<b>600(L) x 55(H) x 180(W)</b>

The above specifications shall be modified by manufacturer for improvement without prior notice.

# SPECIFICATIONS

## ■ DC-501

Rated power output

-RMS power, 4 ohms mono ----- **350W x 1CH**

-RMS power, 2 ohms momo -----**500W x 1CH**

Signal to Noise Ratio ----->**85dB**

Frequency Response -----**20Hz ~ 20KHz (+/-0.5dB)**

THD@RMS Watts -----**0.013%**

Slew rate ----->**25 V/μS**

Damping factor ----->**600@4Ω**

Fuse Rating ----- **20A x 3**

Input Sensitivity ----- **500mV~10V (+/- 5%)**

Dimensions (mm) -----**340(L) x 55(H) x 180(W)**

## ■ DC-1101

**800W x 1CH**

**1200W x 1CH**

>**95dB**

**20Hz ~ 20KHz (+/-0.5dB)**

**0.03%**

>**40 V/μS**

>**800@4Ω**

**40A x 3**

**500mV~10V (+/- 5%)**

**600(L) x 55(H) x 180(W)**

## ■ DC-656

Rated power output

-RMS power, 4 ohms stereo ----- **50W x 4CH + 100W x 2**

-RMS power, 2 ohms stereo ----- **90W x 4CH + 180W x 2**

Signal to Noise Ratio ----->**95dB**

Frequency Response ----- **20Hz ~ 20KHz (+/-0.5dB)**

THD@RMS Watts ----- **0.02%**

Channel Separation ----->**23 V/μS**

Slew rate ----- **60dB**

Damping factor ----->**160@4Ω**

Fuse Rating ----- **40A x 3**

Input Sensitivity ----- **500mV~10V (+/- 5%)**

Dimensions (mm) ----- **600(L) x 55(H) x 180(W)**

The above specifications shall be modified by manufacturer for improvement without prior notice.

# TROUBLE SHOOTING GUIDE

*This power amplifier has protection features to prevent most forms of damage.*

*If the unit senses excessive heat, short circuited speakers or overload, the protection indicators will be lit and the system will be turned off. Prior to checking the wiring for any fault, you should turn all level controls down and turn off power. If the amplifier shuts down due to excessive heat, the protection indicators will not be lit: simply allow the amplifier to cool down.*

*Before removing your amplifier, refer to the list below and follow the suggested procedures. Always test the speakers and their wires first.*

## **AMPLIFIER IS NOT POWERED UP**

- ◆ Check if at least +12V DC is present on the battery power terminal.
- ◆ Check if at least +13.8V DC is present on the remote terminal.
- ◆ Check if a good ground connection is present. Check all fuses.
- ◆ Check if the protection LED is not lit.

## **PROTECTION LED ILLUMINATES WHEN AMPLIFIER IS POWERED UP**

- ◆ Check to see if any speaker wires are short-circuited to the chassis or themselves.
- ◆ Remove speaker wires and reset the amplifier. If the protection LED still comes on, then the amplifier is at fault.

## **FUSE BLOWING**

- ◆ Check if the minimum speaker impedance is met.
- ◆ Check for short-circuits on power cable and vehicle chassis.

## **OVERHEATING**

- ◆ Check if the minimum speaker impedance is met.
- ◆ Check speakers for short-circuits.
- ◆ Check if there is good airflow around the amplifier.

## **SOUND TOO LOW-DISTORTED SOUND**

- ◆ Check if the input level control is set to match the output level of the source unit.
- ◆ Check the head unit's volume.
- ◆ Check speakers for short-circuits.
- ◆ Check if crossover frequencies have been properly set.

## **HIGH HISSING NOISE - ENGINE NOISE IN SPEAKERS**

- ◆ Check if a good ground connection is present. Most engine noises are caused by grounding issues.
- ◆ Hissing noise is most often caused by gain issues. Proper gain matching is usually required to eliminate hissing noise.

## Technical Assistance

Should you experience a problem with your DSP6-SL or DRC-SL, please contact the dealer that sold you this product. If your dealer is unable to solve your problem, you may contact the factory service department directly.

Phone: (209) 577-4268 Monday - Friday, 8AM - 5PM Pacific Standard Time FAX: (209) 577-8548

Also, check our web page, [www.zapco.com](http://www.zapco.com), for tips. You can also e-mail for technical help directly from our web page.

If you need to return this product for repair, please call the factory for a Return Materials Authorization (RMA) number. We will ask you for information that will include your name, return shipping address, daytime phone number, model and serial number, and a detailed description of your problem. A photocopy of your original purchase receipt is necessary to determine warranty status and should also be included. Once we issue you an RMA, please write it in a highly visible area on the package. ZAPCO will not accept any packages that do not have a valid RMA number clearly marked on the outside of the package.

Once you have a valid RMA number, send all repairs to:

A.R.P.A. of America Corp. / Zapco

Attn.: Service Department

3037 E Palm Ave Suite 102, Manteca, CA 95337



ARPA of America Corporation  
3037 E Palm Ave Suite 102  
Manteca, CA 95337  
Phone: (800) 47-Force

The Zapco DC-Series is a joint venture of ARPA of America  
and ARPA Italy and manufactured in Korea