

CODICE/CODE: **ZLS120185**

Batteria sigillata AGM DEEP-CYCLE (uso ciclico) al silicone
Silicon DEEP-CYCLE AGM maintenance free battery



Volt		12V
Capacity/capacità (20h)		105Ah
Capacity/capacità 25°C	10h	90Ah
	5h	85Ah
	2h	71Ah
Internal Resistance	Full Charged Battery 25°C	≤5.3m Ω
Capacity affected by Temperature/Effetti della temperature sulla capacità	40°C	102%
	25°C	100%
	0°C	85%
Self-Discharge 25°C Capacity / Autoscarica a 25°C	after 3 month storage	90%
	after 6 month storage	80%
	after 12 month storage	62%
Charge cycle/ Ciclo di carica	IU + h	"In" max. 20Amp; "V1" 2.43V/cell
	IUIa	"In" max. 20Amp; "V1" 14.4Volt; "If" 1Amp.

Battery Dimensions/ Dimensioni batteria	L/L	307mm
	W/P	169mm
	H/A	211mm
	Tot- H/A	215mm
Box Dimensions/ Dimensioni scatola	L/L	322mm
	W/P	184mm
	H/A	251mm
Weight/peso		30.5Kg
Terminal/terminal		M8
Case/contenitore		ABS

Amp. (25°C)

F.V/Time	5min	10min	15min	30min	45min	1h	2h	3h	5h	8h	10h	20h
1.60V	237.6	151.5	128.7	82.2	60.4	55.4	35.2	24.8	16.8	11.1	9.9	5.5
1.65V	233.3	148.7	126.4	80.7	59.3	54.4	34.6	24.3	16.5	10.9	9.7	5.4
1.70V	229.0	146.0	124.0	79.2	58.2	53.4	34.0	23.9	16.2	10.7	9.5	5.3
1.75V	224.6	143.2	121.7	77.7	57.1	52.4	33.3	23.4	15.9	10.5	9.4	5.2
1.80V	216.0	137.7	117.0	74.7	54.9	50.4	32.0	22.5	15.3	10.1	9.0	5.00

Watts (25°C)

F.V/Time	5min	10min	15min	30min	45min	1h	2h	3h	5h	8h	10h	20h
1.60V	457.4	291.6	247.7	158.2	116.3	106.7	67.8	47.6	32.4	21.3	19.1	10.6
1.65V	449.1	286.3	243.2	155.3	114.1	104.8	66.6	46.8	31.8	21.0	18.7	10.4
1.70V	440.7	281.0	238.7	152.4	112.0	102.8	65.4	45.9	31.2	20.6	18.4	10.2
1.75V	432.4	275.7	234.2	149.5	109.9	100.9	64.1	45.0	30.6	20.2	18.0	10.0
1.80V	415.8	265.1	225.2	143.8	105.7	97.0	61.7	43.3	29.5	19.4	17.3	9.6

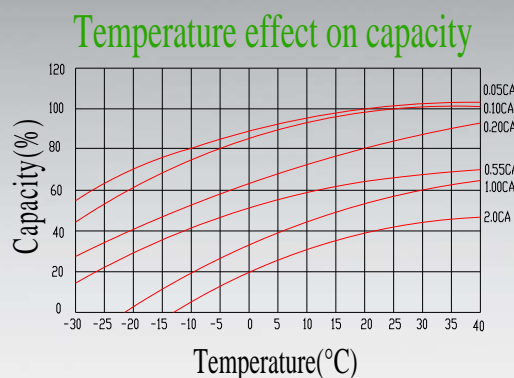
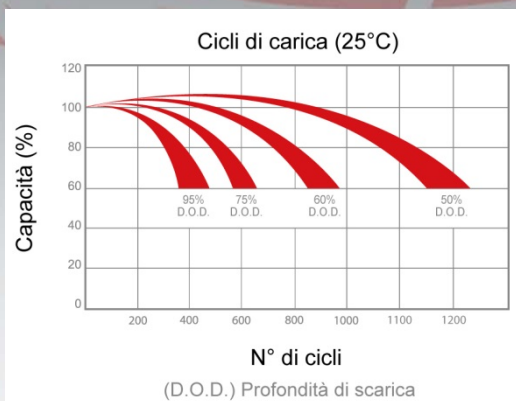
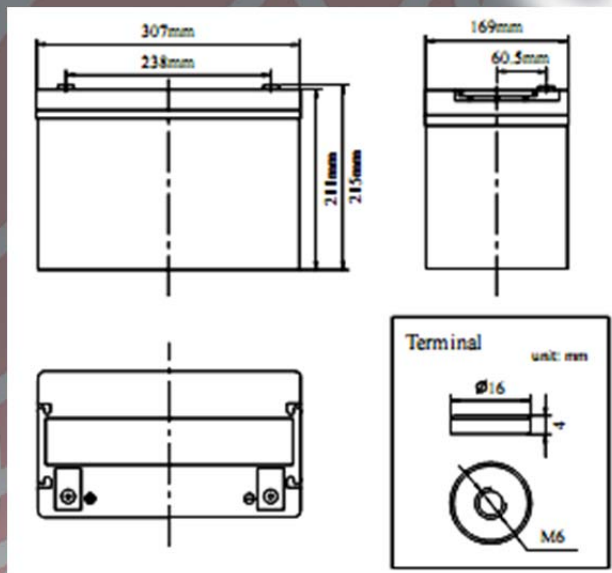

Charge cycle for sealed batteries (GEL/AGM): IU + holding

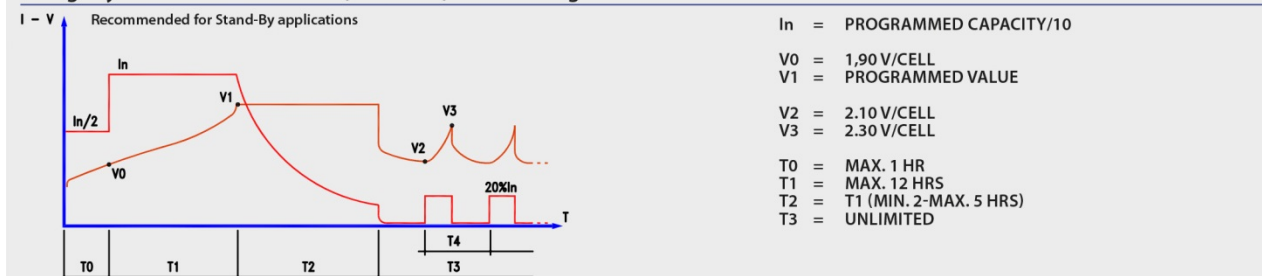

“IUa” charge cycle is always recommended in case of more than 2 batteries in series
Ciclo di carica “IUa” è sempre necessario qualora ci siano più di 2 batterie collegate in serie

IUa charge cycle

