



HIGH-PERFORMANCE CAR-AMPLIFIER

OWNER'S MANUAL

X SERIES
BY AUDIO SYSTEM



X-100.4 MD



DESIGNED AND ENGINEERED BY AUDIO SYSTEM GERMANY

X SERIES
BY AUDIO SYSTEM

SPECIFICATIONS

4-CHANNEL AMPLIFIER	X-100.4 MD
Power Supply Voltage	10 -16 V
Rated Power Output at 14,4 V / 28,8 V	
-RMS power @ 4 Ohm Stereo	4x 100 W
-RMS power @ 2 Ohm Stereo	4x 150 W
Signal to Noise Ratio	> 87 dB
Low Pass Crossover	50 Hz ~ 4000 Hz
High Pass Crossover/ Subsonic Filter	50 Hz ~ 4000 Hz
Frequency Response	10 Hz ~ 40 KHz (+/-1dB)
THD@RMS Watts	< 0.06%
Channel Separation	75 dB
Fuse Rating	2x 25 A
Input Sensitivity	200 mV ~ 6V (+/- 5%)
Dimensions	113(L)x 38(H)x 130(W)mm



AUDIO SYSTEM GERMANY
FALLTORSTRASSE 6 - 76707 HAMBRÜCKEN

DESIGNED AND ENGINEERED BY AUDIO SYSTEM GERMANY

Congratulation on your purchase of your new X-SERIES amplifier.

IMPORTANT: Before installation your power amplifier, we recommend to read the owner’s manual carefully and to follow the instructions regarding connection and fitting exactly.

ATTENTION: Pay attention to advices and instructions of the car manufacturer.

IMPORTANT: Your proof of purchase is evidence of warranty claim for repair or replacement. Keep your proof of purchase, manual and original packaging.

ATTENTION: Use of sound components can impair your ability to hear necessary traffic sounds and may constitute a hazard while driving your automobile.

AUDIO SYSTEMGERMANY accepts no liability for hearing loss, bodily injury or property damage as a result of use or misuse of our products. We recommend installing the equipment by an authorized service center or dealer. A professional fitting and connection is the requirement for further warranty and perfect sound.

X-100.4 MD

- Digital 4-Channel High Power amplifier with Mikro-SMD Technology and MOS-FET PVM Power Supply
- Stable from 8 to 2 ohm stereo
- Variable switchable Low/High and Band Pass Filter from 50 to 4000 Hz
- High-Level-Input with automatically „TURN ON“
- Very fast and steplessly adjustable Music Detection
- Input Sensitivity: variable 200 mV maximum to 6 V minimum
- Multi-Way Protection Circuitry: overheating, overcurrent and short circuitry
- Operating Voltage: DC 10 ~ 16 V Power Input



This power amplifier is featured with an efficient protection system to prevent any damages like over-heating, overvoltage, short-circuit and DC at the loudspeaker output. Occuring an error the protection-LED will light in red. In order to check the problem, first turn down all levels of the head unit, afterwards turn it off.

AMPLIFIER IS NOT POWERED UP, NO LED IS LIGHTENING	<ul style="list-style-type: none"> - ground connection professional connected? - +12V powercable professional connected? - remote cable professional connected? - fuses inserted and alright? - analyze voltage on the amplifier.
PROTECTION LED ILLUMINATES BLUE WHILE AMPLIFIER IS SOUNDLESS	<ul style="list-style-type: none"> - cinch cable alright and professional connected - loudspeaker professional connected? - head unit alright?
PROTECTION LED ILLUMINATES RED WHEN AMPLIFIER IS POWERED UP	<ul style="list-style-type: none"> - amplifier too hot? - short-circuit at the loudspeaker output? - short-circuit caused by loudspeaker cable with vehicle chassis (ground)? - input voltage too high (e.g.faulty generator)?
OVERHEATING (PROTECTION LED ILLUMINATES RED WHEN AMPLIFIER IS POWERED UP)	<ul style="list-style-type: none"> - impedance alright? - loudspeaker error? - adequate airflow of the amplifier? <p style="text-align: center;">! CAUTION ! After cooling down, the amplifier turns on automatically.</p>
ERROR IN AMPLIFIER FUSE	<ul style="list-style-type: none"> - ground professional connected? - loudspeaker impedance alright? <p style="text-align: center;">! CAUTION ! Make sure when changing fuses to use the same value.</p>
SOUND TOO LOW OR LOW-DISTORTED SOUND	<ul style="list-style-type: none"> - input level control "GAIN" is set to match the head unit? - output level control of the head unit alright? - loudspeaker error? - loudspeaker cable checked? - crossover frequencies has been properly set? (Check head unit, ampliflier, DSP, sound processor, equalizer, frequency bandpassfilter...)
HIGH HISS-ENGINE NOISE IN SPEAKERS	<ul style="list-style-type: none"> - ground connection professional connected? - short-circuit caused by loudspeaker cable with vehicle chassis (ground)? - cinchcable (RCA) and/or loudspeaker cabel installed too close to the power connection cable? - cinch ground (RCA) of the head unit alright?

⚠ ATTENTION ⚠

Please contact your specialized dealer if the amplifier is still not working after it has been checked with the error list!

For warranty ajustement / repairs the original invoice has to be attached!
Opening the power amplifier is leading to a lost of warranty in either case!

X-100.4 MD

Full-Aktiv-Mode

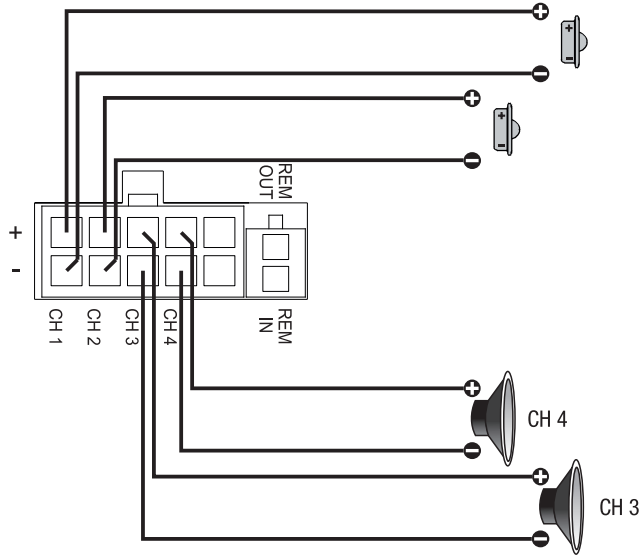

Speaker impedance
2 ~ 8 ohm

X-100.4 MD

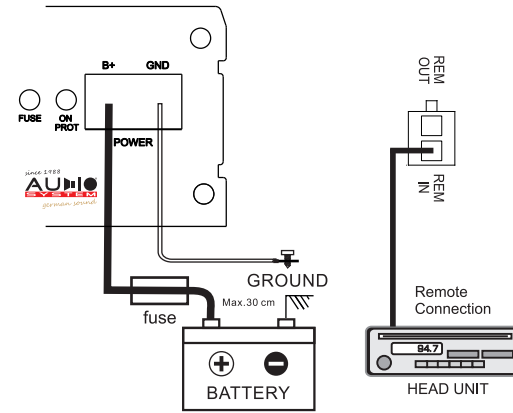

1. Battery disconnection:
First, disconnect the power supply of the vehicle by removing the ground cable of the battery.

2. Ground connection:
Connect the GND (ground) connection of the amplifier with the car chassis. Keep this cable as short as possible (not longer than 50 cm) and use a suitable cross section. Make sure, that the connection with the vehicle chassis is free of paint, dirt and dust.

3. +12 V Power connection:
Connect the +12 V contact of the amplifier with the supply cable via a fuse directly to the vehicle battery. Keep in mind, that the length of the cable from fuseholder to vehicle battery has to be maximum 30cm. For the amplifier to function at its best, use a high quality fuse holder and suitable cable. This fuse protects the amplifier and the vehicle against the possibility of a short circuit in the power cable.

4. Remote connection:
Connect the REM-terminal of the amplifier to the remote-output (automatic 12 V antenna-output) of the head unit. Use a 0,5 - 1,5 mm² power cable.

⚠ ATTENTION ⚠

Please follow the instructions during the installation of your amplifier:

- Take care of a professional attachment. Pay attention, that no electrical cable, gas tank, hydraulic breakes or other components get damaged.
- There has to be enough cooling and air circulation. Avoid the installation in small closed boxes or close to heating parts.
- Protect the amplifier from fluids, wetness, heat and foreign material as well as from other influences.
- The amplifier is only to be built into vehicles with a 12 V DC power supply.
- Never install the power supply cable with other original wires of the vehicle (gas cables), fan motors, brand control moduls etc.
- Install the signal cable (cinch cable) as well as the speaker cable far away of the power cables to avoid troubles with the music signal.
- The cables of your amplifier have to be installed, so that there is no danger of binding, squeezing or breaking.

X-100.4 MD

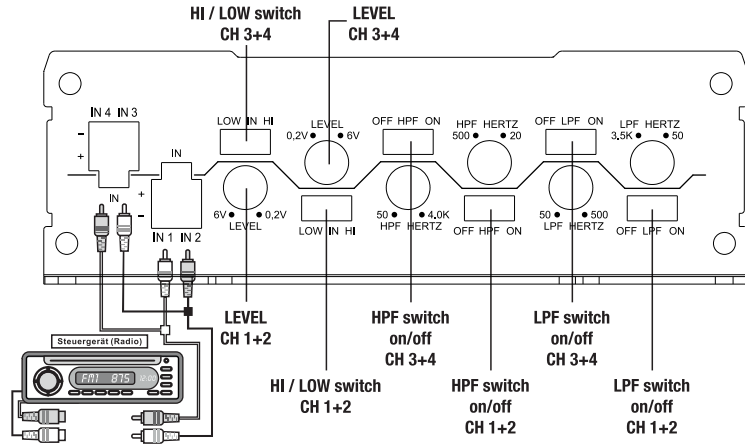

The **X-SERIES** amplifiers have connectors with, which are connected by RCA cables to the preamp outputs of the head unit. If this is not possible (usually in an original radio, OEM) the speaker outputs of the car radio can be connected directly to the wired inputs of the amplifier. In this case, the Input Mode must be switched to "HI". **It is important that the level pots are first set to minimum and turned up carefully when handling.**

The power stage is automatically turned on when a signal is present. Accessories can be purchased in stores such as adapter cable **HLAC** and **RCA HI**. Using the variable high pass filter (HPF) - and low-pass filter (LPF), the level knob can be seen on his personal tastes, on the characteristics of the car and the speakers set the amplifier individually. At **X-100.4 MD** is also a fully active solution possible).

AUDIO SYSTEM GERMANY, recommends that you leave your amplifier set by a specialist company, specialist dealer or a specialist to meet your needs.

The **X-SERIES** power amplifier has a signal auto-detection. This is required if the OEM output has no overlying 6-volt DC signal. To turn on the signal detection, the switch position from **BTL to SE** has to be set (see fig.).

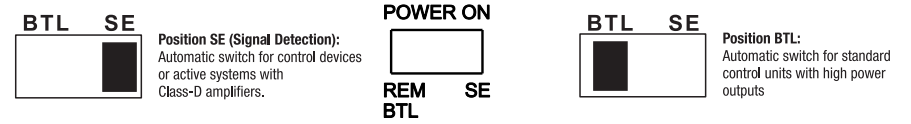

4-Kanal Stereo-Betrieb

